

DETAIL A
FLOOR SHEATHING PLACEMENT
SCALE: 1/2"=1'-0"

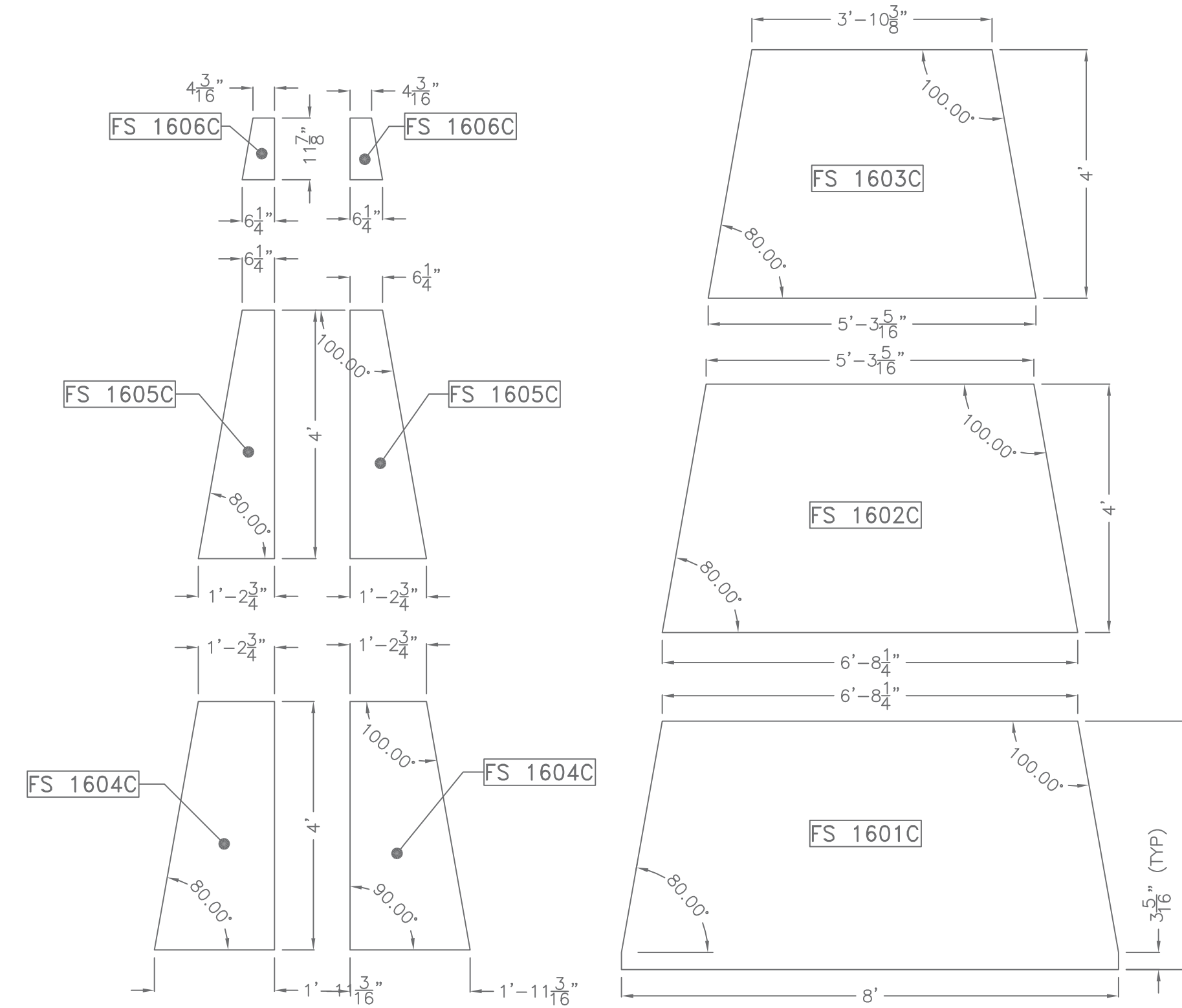

DETAIL B
FLOOR SHEATHING COMPONENT DETAILS
SHEATHING MATERIAL: (18 PIECES OF EACH REQUIRED) 5/8" CDX PLYWOOD
SCALE: 1/2"=1'-0"

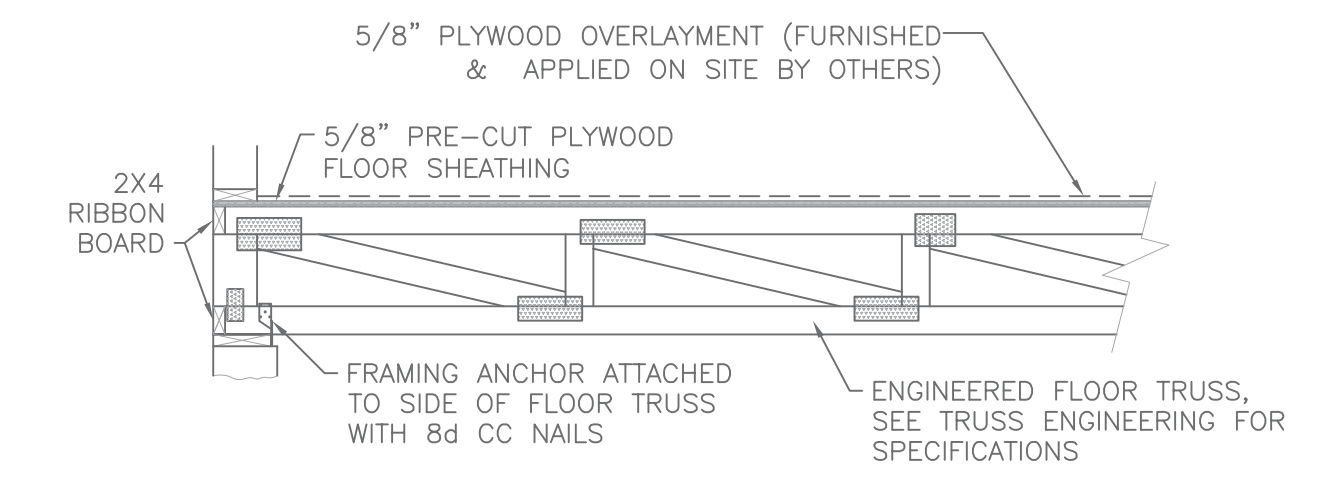

DETAIL C
TYPICAL FLOOR TRUSS
SCALE: 1/2"=1'-0"

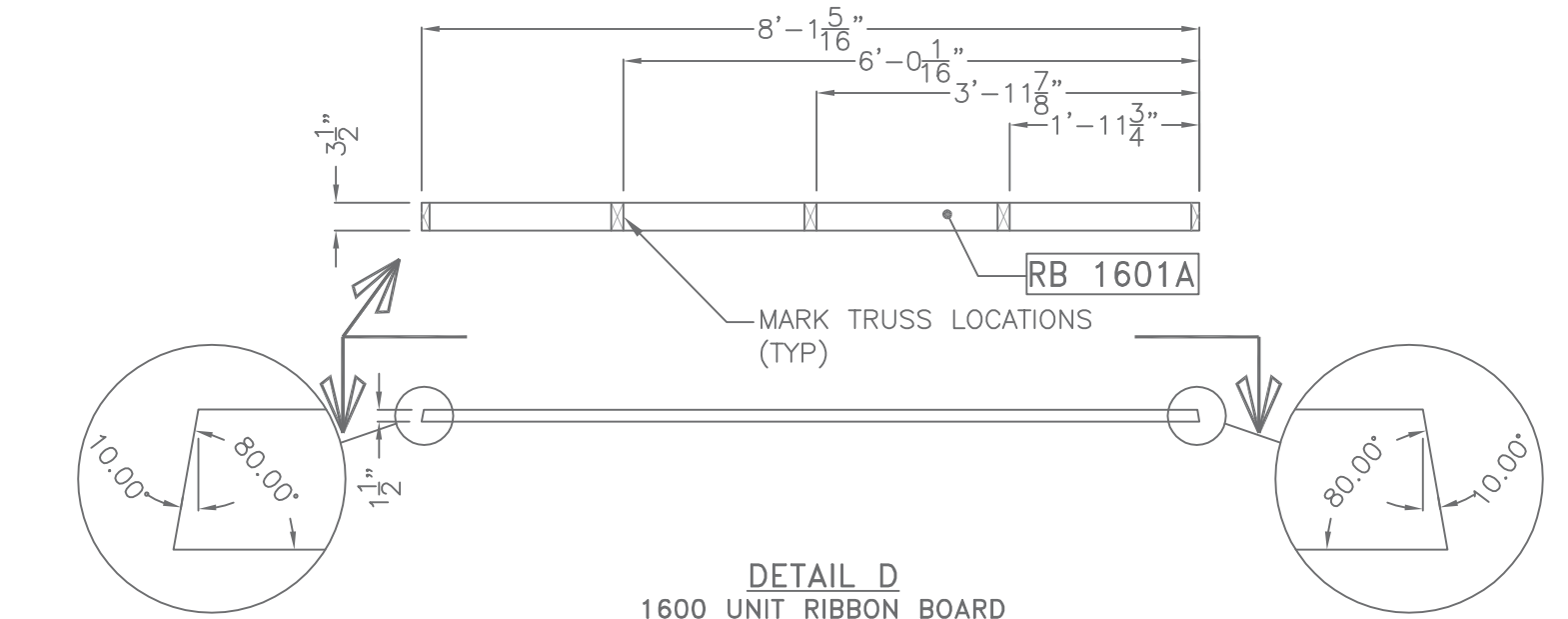

DETAIL D
1600 UNIT RIBBON BOARD
(36 REQUIRED)
SCALE: 1/2"=1'-0"

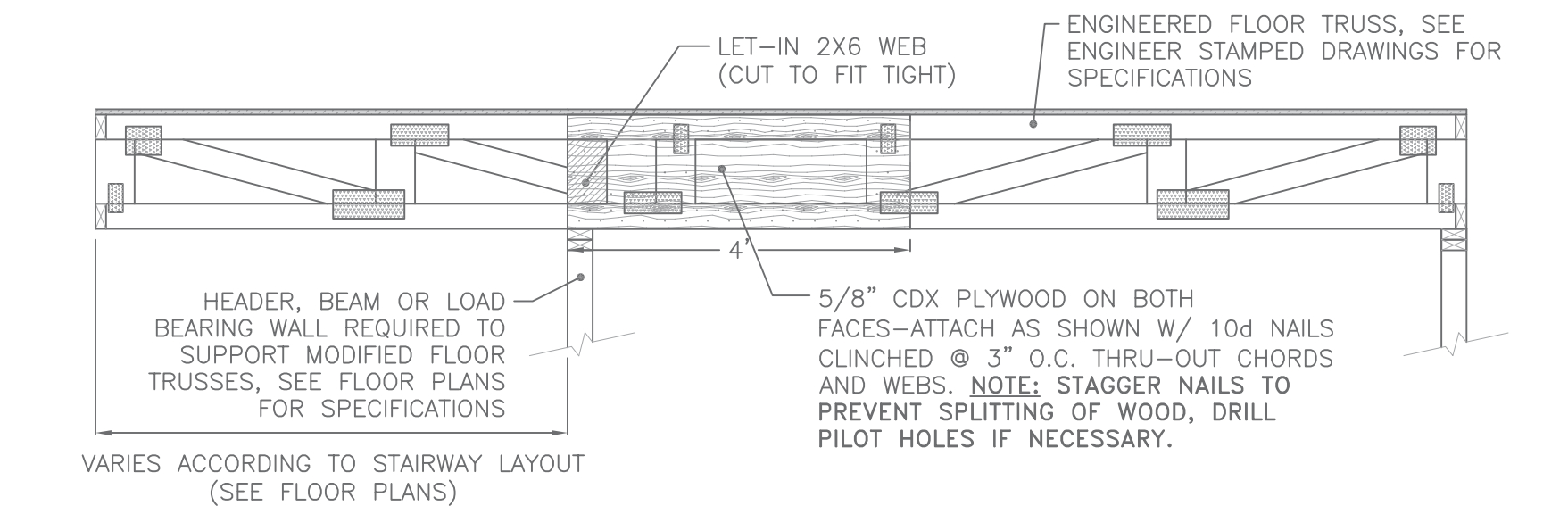

DETAIL E
FIELD FIX FLOOR TRUSS
SCALE: 1/2"=1'-0"

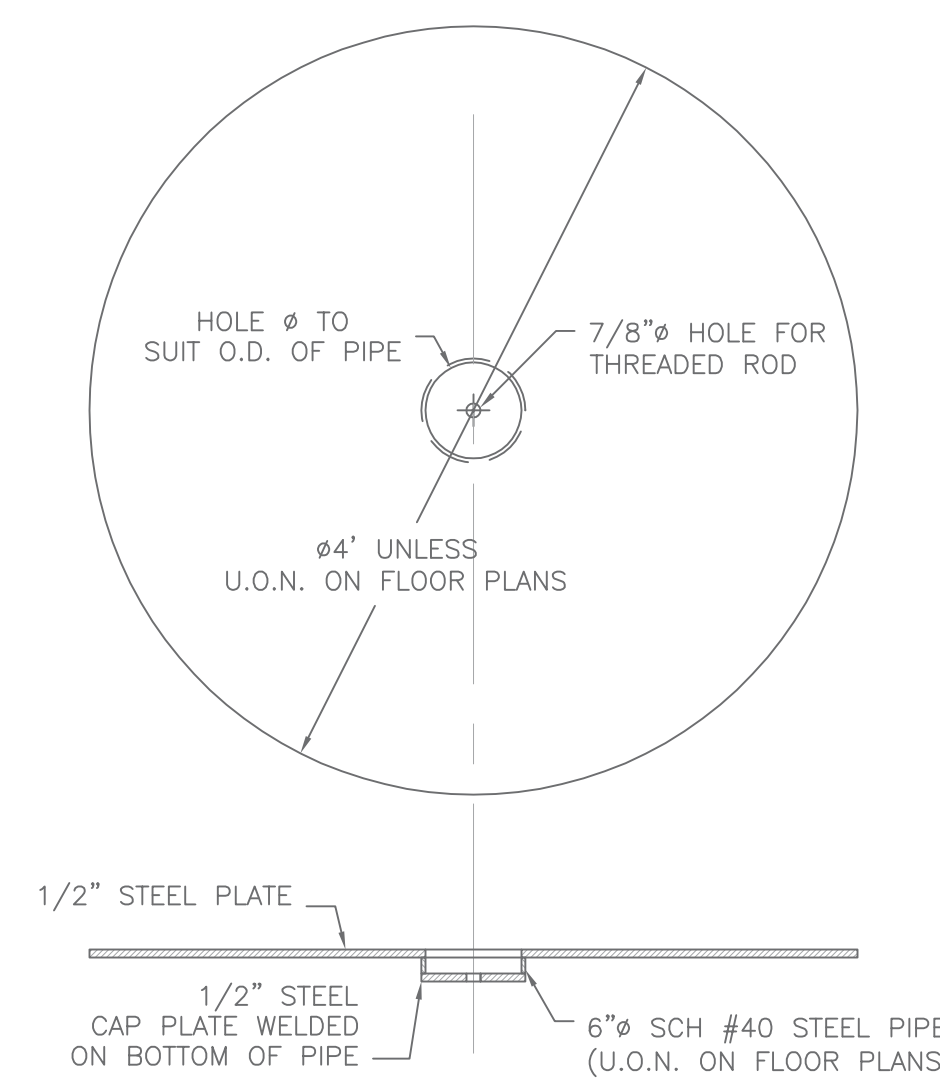

DETAIL F
TOP PLATE
MODELS 1500-2000
SCALE: 1"=1'-0"

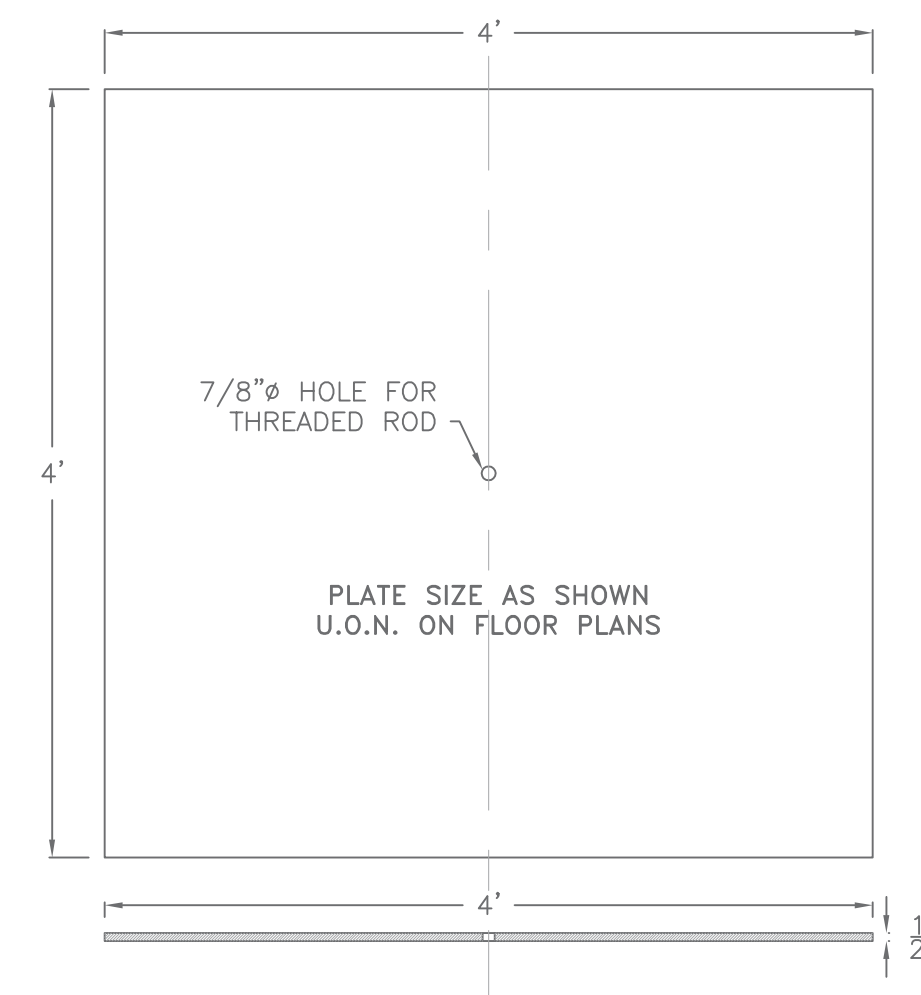

DETAIL G
FLOOR PLATE
MODELS 1600-2000
SCALE: 1"=1'-0"

DRAWING TITLE: FLOOR DETAILS	
1600 MODEL	
SCALE: AS NOTED	DRAWN BY: STAFF
DATE: 12/04/09	REVISION DATE: --
FILE LOCATION: K/GENS 2009/PAGE 4/1600 FLOOR DETAILS	

SHEET NO:
4

DELTEC HOMES IS AN EQUAL OPPORTUNITY EMPLOYER. ALL INFORMATION CONTAINED HEREIN IS THE PROPERTY OF DELTEC HOMES AND IS TO BE USED ONLY FOR THE PROJECT AND SITE SPECIFICALLY IDENTIFIED. ANY REPRODUCTION OR TRANSMISSION OF THIS INFORMATION WITHOUT THE WRITTEN PERMISSION OF DELTEC HOMES IS STRICTLY PROHIBITED. © 2009 DELTEC HOMES. ALL RIGHTS RESERVED.